

PROFI^{PAQ}-L



Universal high-performance PROFIBUS-PA transmitter For DIN-rail mounting

MAIN FEATURES

PROFI^{PAQ}-L is a universal temperature transmitter with additional voltage and resistance input. It is designed according to the latest PROFIBUS-PA standard for temperature transmitters, i.e. Profile version 3, Class A & B

Thanks to the digital output, PROFIPAQ-L offers very accurate measurements as well as sensor and process information. With double inputs new features, such as two redundant Pt100 in 3-wire connection, are available.

Configuration from a PC with Inor software or over the PROFIBUS network is possible.

PROFIBUS-PA

- UP to 125 transmitters in one Profibus network
- Profile 3.0, Class A & B
- Intrinsically Safe applications
- High noise immunity

Time and cost saving PC configuration

- With the Inor Windows software ProfiSoft
- Direct connection from PC to transmitter, without costly PROFIBUS tool
- Complete set-up, including transmitter address, before installation

PROFIBUS configuration - Up to 8 masters

- From 1 to 8 PROFIBUS Master Devices (Master Class 2) over the PROFIBUS network
- Integrated in the Siemens Simatic Step7/PDM system

Universal double inputs

- Accepts RTD, Thermocouple, mV and Ohm
- Double inputs for RTD (3-wire connection), T/C and mV

Multiple outputs

- Measured value of Input 1 and Input 2
- A value calculated from Input 1 and 2: Difference, Average, Minimum and Maximum
- Redundancy with double sensor elements

High accuracy

- Typical accuracy for Pt100: $\pm 0.1^{\circ}\text{C}$
- Very low temperature drift
- Accurate CJC
- Sensor matching

Customized linearization *

- 50 point linearization – any sensor can be matched

Sensor monitoring

- Sensor aging (with double sensor inputs)*
- Low sensor isolation - SmartSense*
- Sensor break and short-circuit

Easy installation and maintenance

- Plug-in screw terminals

Rugged design

- 1500 VAC input/output isolation
- Excellent EMC performance
- Rugged industrial terminals

* Available if configured with INOR software ProfiSoft

PO Box 9125, SE-200 39 Malmö, Sweden, PHONE +46 40 312560, FAX +46 40 312570, E-MAIL info@inor.se WEB www.inor.se

INOR TRANSMITTER OY

PHONE +358 9 83850210, FAX +358 9 83850219, E-MAIL js.inor@surfeu.fi

INOR TRANSMITTER GmbH

PHONE +49 6181 582940, FAX +49 6181 582944, E-MAIL inor.gmbh@t-online.de

INOR TRANSMITTER Inc.

PHONE +1 262 884 4535, FAX +1 262 884 4537, E-MAIL service@inor.com

www.inor.com

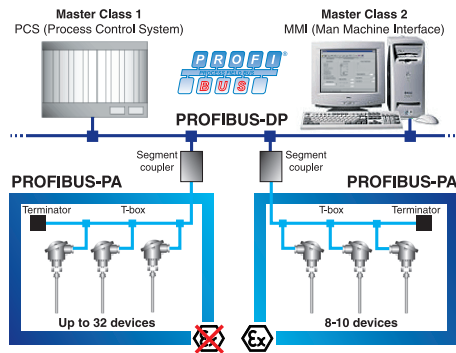

PROFIBUS is a fieldbus network for digital communication over a 2-wire architecture based on the international standard EN 50170. Two levels are used in a PROFIBUS network: the high level PROFIBUS-DP used for process control and the field level PROFIBUS-PA used for field instrumentation.

PROFIBUS-DP Short specification

- High speed - up to 12 000 kBit/s
- 2-wire cable
- RS 485 transmission technology

PROFIBUS-PA Short specification

- Medium speed - 31.25 kBit/s
- 2-wire cable
- IEC 1158-2 transmission technology
- Supports Intrinsically Safe installations
- The transmitter power is supplied over the bus cable



Configuration

PROFIPAQ-L can be configured in two different ways:

- With the Inor Windows software ProfiSoft and a direct connection from PC to the separate communication port of the transmitter. This is a time and cost saving alternative to configuration over the PROFIBUS. The configuration is made without costly PROFIBUS tools (software, interface and segment coupler). The complete set-up, including transmitter address, can be carried out before the installation in the network. Besides normal configuration, ProfiSoft can be used for basic calibration of PROFIPAQ-L, saving of configuration files for future use and printing of configuration protocols. ProfiSoft is compatible with Windows 95, 98, NT4.0, 2000 and XP. The program is menu driven and easy to learn. On-line help at the fingertip is an effective tool for all users.
- From up to 8 PROFIBUS Master Devices (Master Class 2), for instance a PC or a PCS (Process Control System) with PROFIBUS interface and integrated configuration software, via a segment coupler. The DD (Device Description) for PROFIPAQ-L is integrated in the Siemens PDM system.

Accuracy and stability

PROFIPAQ-L is designed for applications with the highest demands on accuracy and stability under severe operating conditions.

Low linearity and calibration errors - The combination of a highly efficient 50-point linearization and precision calibration equipment reduces these errors to a minimum (See Specifications).

Temperature and long-term stability - The reduction of analog circuits (digital output) and the use of quality components give excellent stability for temperature changes and over time (See Specifications).

Measurements with RTD's and other resistances

PROFIPAQ-L accepts inputs from standardized Platinum and Nickel RTDs like Pt10...Pt1000 acc. to IEC 60751 (a=0.00385) and JIS 1604 (a=0.003916) and Ni50...Ni1000 acc. to DIN 43760, as well as inputs from plain resistance sensors such as potentiometers (max. 4000 ohm). 2-, 3- or 4-wire connection can be chosen.

Measurements with thermocouples and plain voltage

PROFIPAQ-L accepts inputs from 12 types of standardized thermocouples as well as plain mV input (max. 1000 mV). For T/C input, the CJC (Cold Junction Compensation) is either fully automatic, by means of an internal accurate sensor, remote with Pt100 sensor or fixed by entering an external CJ temperature.

Double inputs for RTD, thermocouples and voltage

Double inputs are available and can be used for arithmetic calculation such as difference, average and min./max. measurement. Redundancy between two sensors can be activated.

Multiple outputs

When using double inputs for RTD, Thermocouples or mV, 3 output values are available: Each measured value of input 1 and 2 plus the value calculated from input 1 and 2, e.g. Difference, Average, Minimum and Maximum.

Customized linearization*

The accurate and versatile 50-point Customized linearization can be used to create any type of linearization curve for RTD, T/C, resistance and mV inputs. The transmitter can be programmed to provide a correct process value in a choice of engineering units for a sensor with non-linear input/output relation.

Sensor matching

This function corrects known sensor offset errors.

Mounting

PROFIPAQ-L is designed for mounting on 35 mm DIN-rail. Rugged plug-in screw terminals with coding for safe connections.

Sensor failure monitoring

PROFIPAQ-L monitors sensor break and short-circuit. When any sensor lead is broken or short-circuited, a fault indication will be transmitted over the PROFIBUS.

The monitoring is furnished with a pulsed excitation current. This eliminates the voltage drop in the lead wires (giving a measuring error), caused by a standard DC excitation current.

Sensor aging monitoring*

If a RTD or thermocouple with double sensor elements is used, PROFIPAQ-L can often detect sensor aging by checking the reading from both elements. Too big a difference will indicate sensor aging, and fault indication will be transmitted over the PROFIBUS.

SmartSense - Sensor isolation monitoring*

SmartSense continuously monitors the isolation resistance of thermocouples and RTDs as well as the cabling between sensor and transmitter. PROFIPAQ-L will react by transmitting fault indication over the PROFIBUS if the isolation resistance is below a user defined level. SmartSense requires an extra lead inside the thermocouple or RTD.

Adjustable damping

For smoothing down instabilities on the input, an additional damping, with a time constant of 0 to 60 seconds, can be activated.

*Only available if configured with Inor software ProfiSoft

S P E C I F I C A T I O N S

Input RTD		2-, 3- and 4-wire connection
Pt10	(IEC60751, $\alpha=0.00385$)	-200 to +850 °C
Pt50	(IEC60751, $\alpha=0.00385$)	-200 to +850 °C
Pt100	(IEC60751, $\alpha=0.00385$)	-200 to +850 °C
Pt200	(IEC60751, $\alpha=0.00385$)	-200 to +850 °C
Pt500	(IEC60751, $\alpha=0.00385$)	-200 to +850 °C
Pt1000	(IEC60751, $\alpha=0.00385$)	-200 to +850 °C
Pt X ($10 \leq X \leq 1000$)	(IEC60751, $\alpha=0.00385$)	-200 to +850 °C
Pt10	(JIS1604, $\alpha=0.003916$)	-200 to +850 °C
Pt50	(JIS1604, $\alpha=0.003916$)	-200 to +850 °C
Pt100	(JIS1604, $\alpha=0.003916$)	-200 to +850 °C
Ni50	(DIN 43760)	-60 to +250 °C
Ni100	(DIN 43760)	-60 to +250 °C
Ni120	(DIN 43760)	-60 to +250 °C
Ni1000	(DIN 43760)	-60 to +250 °C
Sensor current		~250 μ A
Maximum sensor wire resistance		25 Ω / wire
Input Resistance		
Potentiometer / Resistance		2-, 3- and 4-wire connection
Low range		0 to 400 Ω
High range		0 to 4000 Ω
Customized linearization		Up to 50 points
Sensor current		~250 μ A
Maximum sensor wire resistance		25 Ω / wire
Input Thermocouple		
T/C B	Pt30Rh-Pt6Rh (IEC 60584-1)	400 to +1800 °C
T/C C	W5-Re (ASTME 988)	0 to +2315 °C
T/C D	W3-Re (ASTME 988)	0 to +2315 °C
T/C E	NiCr-CuNi (IEC 60584-1)	-200 to +1000 °C
T/C J	Fe-CuNi (IEC 60584-1)	-200 to +1000 °C
T/C K	NiCr-Ni (IEC 60584-1)	-200 to +1350 °C
T/C L	Fe-CuNi (DIN 43710)	-200 to +900 °C
T/C N	NiCrSi-NiSi (IEC 60584-1)	-200 to +1300 °C
T/C R	Pt13Rh-Pt (IEC 60584-1)	-50 to +1750 °C
T/C S	Pt10Rh-Pt (IEC 60584-1)	-50 to +1750 °C
T/C T	Cu-CuNi (IEC 60584-1)	-200 to +400 °C
T/C U	Cu-CuNi (DIN 43710)	-200 to +600 °C
T/C Custom	50 point linearization	-10 to +100 mV
Input impedance		>10 M Ω
Maximum sensor wire resistance		500 Ω (total sensor loop)
Cold Junction Compensation (CJC)		Internal, remote (Pt100) or fixed
Input Voltage		
Low range		-10 to +100 mV
High range		-10 to +1000 mV
Customized linearization		Up to 50 points
Input impedance		>10 M Ω
Maximum sensor wire resistance		500 Ω (total loop)
Double inputs for RTD, Thermocouple and Voltage		
Differential	Output value:	Ch1 - Ch2 or Ch2 - Ch1
Average	Output value:	0.5 * (Ch1 + Ch2)
Average with redundancy	Output value:	0.5 * (Ch1 + Ch2), Ch1 or Ch2 if the other one is broken
Minimum	Output value:	Min (Ch1, Ch2)
Maximum	Output value:	Max (Ch1, Ch2)
Output		
Serial output		Acc. to IEC 1158-2
Cyclic communication w. Master Class 1		Measured values of input 1 and 2, calculated values, status information
Update time		~ 1 s
Acyclic communication w. Master Class 2		Transmitter configuration, measured values of input 1 and 2, calculated values, status information. Up to 8 masters possible.
General data		
Adjustable damping time		0 to 60 s
Isolation		1500 VAC, 1 min
Power supply	From segment coupler	9 to 32 VDC
Mounting		Rail acc. to DIN EN50022, 35 mm
Environment conditions		
Ambient temperature	Storage	-20 to +70 °C
	Operating	-20 to +70 °C
Humidity		0 to 95 %RH
Vibration		Acc. to IEC 60068-2-6, test Fc, 10 to 500 Hz, 5 g
Shock		Acc. to IEC-60068-2-31, test Ec
EMC	EN standards	EN 61326
	NAMUR recommendation	NE21

SPECIFICATIONS

Resolution and Accuracy

Resolution	Resistance, 0 to 400 Ω	5 mΩ
	Resistance, 0 to 4000 Ω	50 mΩ
	Voltage, -10 to 100 mV	0.5 μV
	Voltage, -10 to 1000 mV	5 μV
Accuracy	RTD and Thermocouple	Depends on sensor type
	Resistance, 0 to 400 Ω	40 mΩ (@ 25 °C incl. calibration and linearity errors)
	Resistance, 0 to 4000 Ω	400 mΩ
	Voltage, -10 to 100 mV	10 μV
	Voltage, -10 to 1000 mV	100 μV
Cold Junction Compensation (CJC)	RTD and Thermocouple	See table below
	Internal comp.	±0.25 °C
	Remote comp. (Pt100)	Acc. to spec. for RTD
Temperature influence	RTD	±0.001 % of (MV+273)/°C
	Thermocouple Resistance and Voltage	±0.001 % of MV/°C
Temperature influence CJC	Internal comp.	±0.02 °C/°C
	Remote comp. (Pt100)	Negligible
	RTD and Resistance, 2-wire	Adjustable wire resistance compensation
Sensor wire influence	RTD and Resistance, 3-wire	Negligible, with equal wire resistance
	RTD and Resistance, 4-wire	Negligible
	Thermocouple and Voltage	Negligible
	RFI influence	0.15 to 1000 MHz, 10 V/m ±0.5 °C
Long-term stability		Better than ±0.5 °C / year

ACCURACY SPECIFICATIONS FOR RTD AND THERMOCOUPLE INPUT

Specified @ 25 °C. Including calibration and linearity errors. CJC error not included.

Input type	Total temperature range	Temperature range 1	Maximum ¹ measuring error in range 1	Maximum ¹ measuring error outside range 1	Typical ² measuring error in range 1
RTD Pt10	-200 to +850 °C	-200 to +850 °C	1.5 °C	-	0.8 °C
RTD Pt50	-200 to +850 °C	-200 to +850 °C	0.3 °C	-	0.2 °C
RTD Pt100	-200 to +850 °C	-200 to +700 °C	0.15 °C	0.2 °C	0.1 °C
RTD Pt200...Pt1000	-200 to +850 °C	-200 to +850 °C	0.3 °C	-	0.2 °C
RTD Ni50...Ni1000	-60 to +250 °C	-60 to +250 °C	0.2 °C	-	0.1 °C
T/C type B	400 to +1800 °C	+780 to +1800 °C	1.5 °C	3.0 °C	0.8 °C
T/C type C	0 to +2315 °C	0 to +2100 °C	1.0 °C	1.3 °C	0.5 °C
T/C type D	0 to +2315 °C	0 to +2200 °C	1.0 °C	1.2 °C	0.5 °C
T/C type E	-200 to +1000 °C	0 to +1000 °C	0.2 °C	0.5 °C	0.1 °C
T/C type J	-200 to +1000 °C	-100 to +1000 °C	0.3 °C	0.5 °C	0.2 °C
T/C type K	-200 to +1350 °C	-100 to +1350 °C	0.4 °C	0.8 °C	0.2 °C
T/C type L	-200 to +900 °C	-100 to +900 °C	0.3 °C	0.5 °C	0.2 °C
T/C type N	-200 to +1300 °C	+100 to +1300 °C	0.4 °C	1.0 °C	0.2 °C
T/C type R	-50 to +1750 °C	+200 to +1750 °C	1.3 °C	3.0 °C	0.7 °C
T/C type S	-50 to +1750 °C	+200 to +1750 °C	1.3 °C	3.0 °C	0.7 °C
T/C type T	-200 to +400 °C	-100 to +400 °C	0.4 °C	0.7 °C	0.2 °C
T/C type U	-200 to +600 °C	-100 to +600 °C	0.4 °C	0.6 °C	0.2 °C

¹ Conformance level 95 % (2σ)

² Conformance level 68 % (1σ)

CONNECTIONS, DIMENSIONS, ORDERING INFORMATION

INPUT

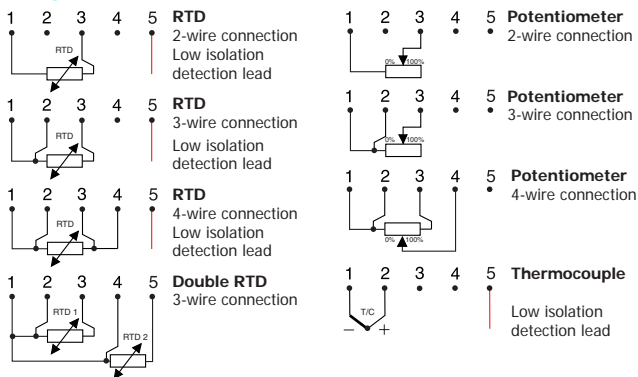

Ordering information

PROFIPAQ-L	70PPL00001
PC configuration kit	70CFG00092
Configuration	70CAL00001

OUTPUT

