

Ceramic Fiber Heaters

Heated Insulation Package

Ceramic fiber heaters offer some of the highest temperature heating element capabilities in the Watlow® family of heaters. Heating units constructed with ceramic fiber insulation isolate the heating chamber from the outside. Ceramic fiber heaters are extremely low mass, high insulation value units with self-supported heating elements. Many applications benefit from the convenience of the heating element and insulation combined into one package. Lightweight, low-density properties make Watlow's ceramic fiber heaters ideal for high-temperature applications requiring low thermal mass.

Features and Benefits

High temperature ICA resistance elements

- Bounds integrally into required position
- Allows five element configurations

Lightweight, low-density alumina-silica composition molded into shape

- Acts as an insulation to isolate the heating chamber from the outside
- Provides low shrinkage fiber and inorganic binder
- Assures a firm, thermal shock resistant, self-supporting unit at all operating temperatures

Operating temperatures up to 2200°F (1204°C)

- Provides high temperature performance that cannot be achieved with many other heater types

Low mass ceramic fiber insulation of 10 to 15 lb/ft³ (160 to 240 kg/m³)

- Allows the heater to reach process temperature quickly
- Enables the energy to heat the load instead of wasting energy on itself

Works directly off common power line voltages

- Eliminates the need for expensive transformers or complex power control systems
- Enables compatibility with the full range of Watlow temperature controllers and power switching devices

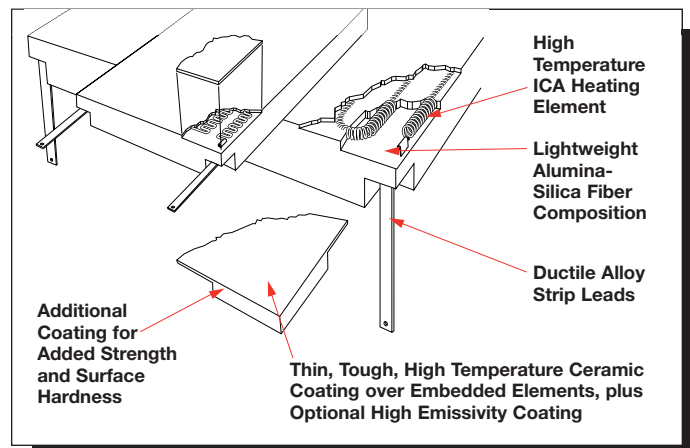

Performance Capabilities

- Operates at temperatures up to 2200°F (1204°C)
- Allows watt densities from 5 to 30 W/in² (0.8 to 4.6 W/cm²)
- Uses "radiant" heat transfer exclusively

Typical Applications

- High temperature furnaces
- Metal melting, holding and transfer
- Semiconductor processing
- Glass, ceramic and wire processing
- Analytical instrumentation

Better Thermal Solutions...Faster

COL-CFH-0311

Options

Embedded Sinuated Elements

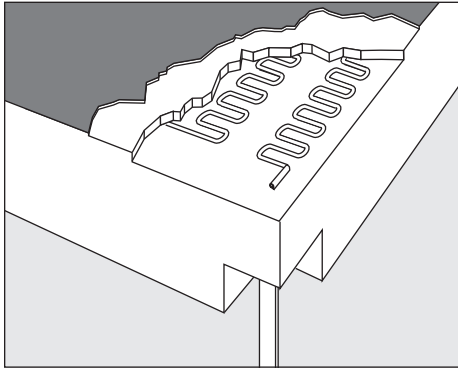

Flat Sinuated

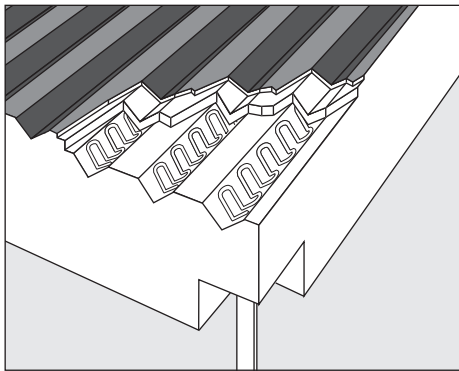

V-Sinuated

Exposed Sinuated Elements

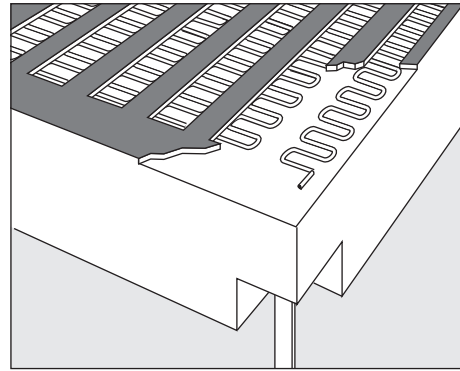

Flat Sinuated

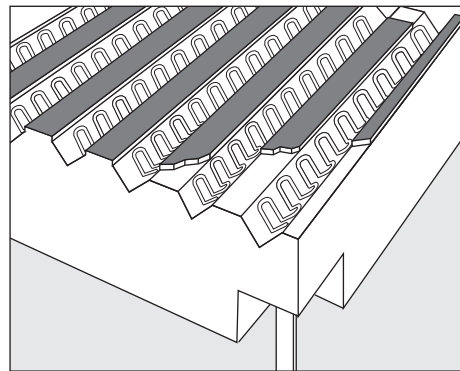

V-Sinuated

- Available in either flat or V-sinuated element configurations
- An advanced V-sinuated element configuration allows up to 27 percent additional watt density over embedded flat sinuated elements
- Performs best at medium to high temperatures at medium watt density power requirements
- Use in partially enclosed to fully enclosed applications
- Especially suited for large, flat units; semi-cylindrical units above 5 in. (125 mm) inside diameter; and full cylinders above 4 in. (100 mm) inside diameter.
- Offers greater effective insulation thickness than coiled element designs
- Enhances “heated insulation” concept of operational use
- Features high emissivity coating on new high-watt density series units.

- Available in either flat or V-sinuated element configurations
- Advanced V-sinuated element configuration allows up to 20 percent additional watt density over that of exposed flat sinuated elements
- Offers the lowest possible wire-to-chamber temperature difference for maximum heater life
- Provides optimum heat-up/cool-down and recovery times as well as maximum efficiency of operation
- Higher current handling capabilities possible
- Minimizes the number of circuits and connections in large furnaces
- Especially well suited for large, flat surface area units and large inside diameter curved units
- Exposed elements are available on special order as a variation of the embedded sinuated element normally provided on stock and standard units.

Termination Options

Watlow offers variations of electric leads to meet particular wiring requirements. To understand the termination options available, it is necessary to understand the different ways electrical leads can be applied.

Ceramic fiber heater electrical leads are welded to stubs – the metal parts that interface between the heating element wire and the add-on electrical leads. These stubs exit the heater at the lead pockets. Pockets are small cavities, below the cold face plane (outside surface) and generally located at or near the corners.

Watlow ceramic fiber heaters are equipped with either strip leads or double twisted wire leads. Strip leads are most commonly used, unless otherwise specified. The various lead styles refer to the lead's exit orientation relative to the pocket used on a given type of heater.

Strip Leads

Flat and semi-cylindrical ceramic fiber heaters are available with the termination options shown. When ordering termination options for catalog units, the specific strip lead **Style** must be specified. To determine the desired style, refer to the illustrations shown on this page. Otherwise, **Style A** leads will be provided and the length will be 12 in. (305 mm). Additional lengths are possible using add-on leads, which are priced per pair, per inch, for the three different widths. See the ordering charts for data on which lead width is used on a specific heater.

Strip leads are shipped with a $\frac{1}{64}$ in. (5 mm) hole at the end of the lead. Use #10-24 screws, nuts and washers, or other wiring connections. Caution should be exercised when making connections. Leads are susceptible to loosening due to thermal expansion and contraction as the heater cycles.

Special Lead Orientation

If the various standard strip lead orientations and pocket configurations are not suitable, special designs are possible.

Leads Bent 90 Degrees

The double twisted leads of full cylinder heaters can be bent 90 degrees to lay into slots and exit to the sides of the unit.

Special Add-On Lead Configurations

The two options illustrated can be welded onto the stub at the heater pocket, or for a better installation, welded on at the end of a specified length of the regular strip lead. The strip lead length can vary from zero to the value necessary to get away from the hot zone. The length of the add-on lead option eliminates the need for a custom product and satisfies a greater range of wiring requirements.

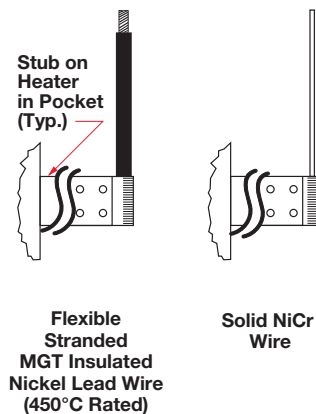

Flat Units

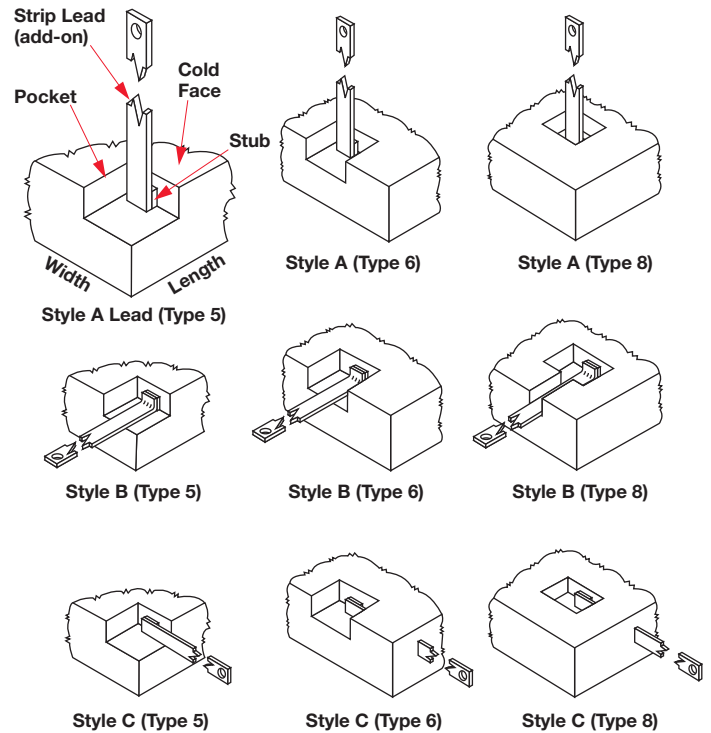

Semi-Cylindrical Units

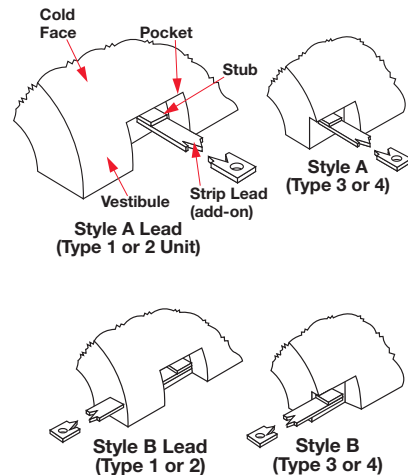

Accessories.

Ceramic fiber heater orders can also include the following accessory items.

Rigidizer

Rigidizer is primarily used to recoat soft, cut edges of ceramic fiber heaters and ceramic fiber insulation panels. Various degrees of hardening can be achieved with additional applications.

B.T.E. Closed-End Thermocouple Tubes

Horizontal thermocouple tube between the elements. Two sizes are available: 0.140 in. (3.6 mm) and 0.265 in. (6.7 mm), both 6 in. (152 mm) long with closed end.

Black Surface Coat

Black high emissivity coating is used to raise emissivity closer to 1.0.

Ceramic Tubes

Ceramic tubes are available in four nominal sizes: $\frac{1}{8}$, $\frac{1}{4}$, $\frac{3}{8}$ and $\frac{1}{2}$ in. (3.2, 6, 9.5 and 13 mm) inside diameter and lengths of 0.9 in. (22 mm) and 1.9 in. (48 mm) long. Ceramic tubes have several uses, including thermocouple mounting holes, mounting pin sleeves and lead coverings.

Dry Heating Surface Mix

Dry heating surface mix is used to make the hot face of all heaters, including those with the high emissivity coating. It can also be used with rigidizer to make a very high temperature paste for touch ups of the hot face area.

Patch Kit

To easily repair small breaks or cracks, the patch kit contains one pint (0.47 L) of powered ceramic fiber, four ounces (0.118 L) of black surface coat. Order **CFPATCHKIT**.

Ceramic Fiber Insulation Blanket

Additional insulation value for ceramic fiber heaters is available with a ceramic fiber insulation blanket. This 6 lb/ft³ (96 kg/m³) ceramic fiber blanket contains no organic binders. It is suitable for applications up to 2300°F (1260°C) and is sold in full rolls or cut by the square foot.

Powdered Ceramic Fiber

Powdered ceramic fiber is used primarily to improve surface finish in critical areas. It can also be used to repair damaged units by filling voids, cracks and broken corners. Use powdered ceramic fiber with rigidizer to make an easily applied paste.

High Temperature Coating and Electrical Potting Cement

Two different high purity, high temperature cements have multiple uses: mount thermocouple tubes, provide extra surface hardening, bond ceramic fiber gaskets and affix lightweight ceramic fiber insulation blanket to panels, as well as attach edge-spacer blocks and custom vestibules.

Strip Lead Porcelain Bushings

Strip lead porcelain bushings are primarily used to protect heater power leads when passing through the metal walls and furnace structures. Bushings are available for use with double twisted leads and the three standard strip lead widths.

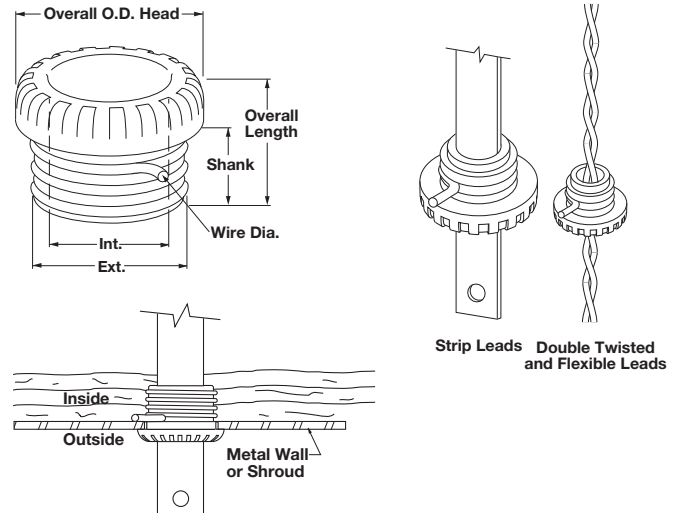

Watlow® is a registered trademark of Watlow Electric Manufacturing Company.

To be automatically connected to the nearest North American Technical Sales Office:

1-800-WATLOW2 • www.watlow.com • inquiry@watlow.com

International Technical Sales Offices: Australia, +61 3 9335 6449 • China, +86 21 3381 0188 • France, +33 1 41 32 79 70
Germany, +49 (0) 72 53 / 94 00-0 • Italy, +39 024588841 • Japan, +81 3 3518 6630 • Korea, +82 2 2628 5770
Malaysia, +60 3 8076 8745 • Mexico, +52 442 217 6235 • Singapore, +65 6773 9488 • Spain, +34 91 675 12 92
Taiwan, +886 7 288 5168 • United Kingdom, +44 (0) 115 964 0777